



49X-6RZ

TRUCK-MOUNTED CONCRETE PUMP

Placing boom	B6RZ 49
Pumping unit	PU1808
Driven by	Gearbox PTO
Chassis	6×4



Technical Specification

BOOM B6RZ 49		
Maximum vertical reach	m	48.6
Maximum horizontal reach (from center of slewing axis)	m	43.6
Maximum depth reach	m	34.6
Minimum unfolding height	m	12.9
Section numbers		6
Boom type		RZ
Pipeline diameter	mm	125
PUMP PU1808		
Maximum theoretical output	m ³ /h	180/120
Maximum theoretical pressure on concrete	bar	83/120
Concrete cylinders (diam. × stroke)	mm	260 × 2100
Hydraulic circuit		Open
CHASSIS		
Chassis brand	m ³ /h	Sinotruk
Engine power	kW	287
Emission standard		Euro 3

Product Highlight

- High Effective: 6-sections boom technology

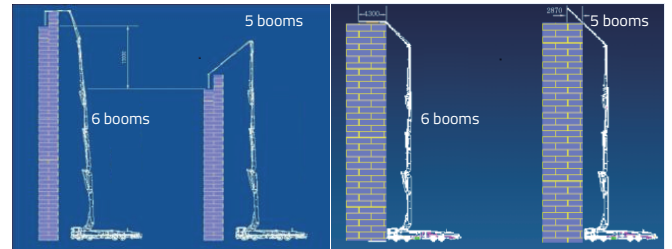

Placing height 13m higher

Placing range 50% larger

- Energy saving

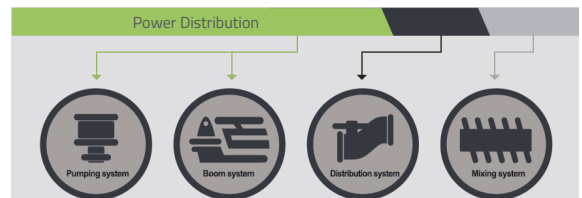

The 4th self-adaptive variable power technology saves fuel by 10%.

- Low Maintenance Cost

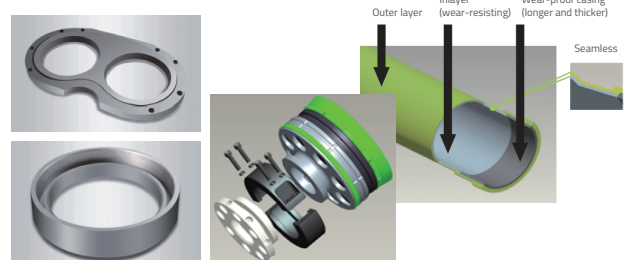

Wearing parts have long service life.



49X-6RZ

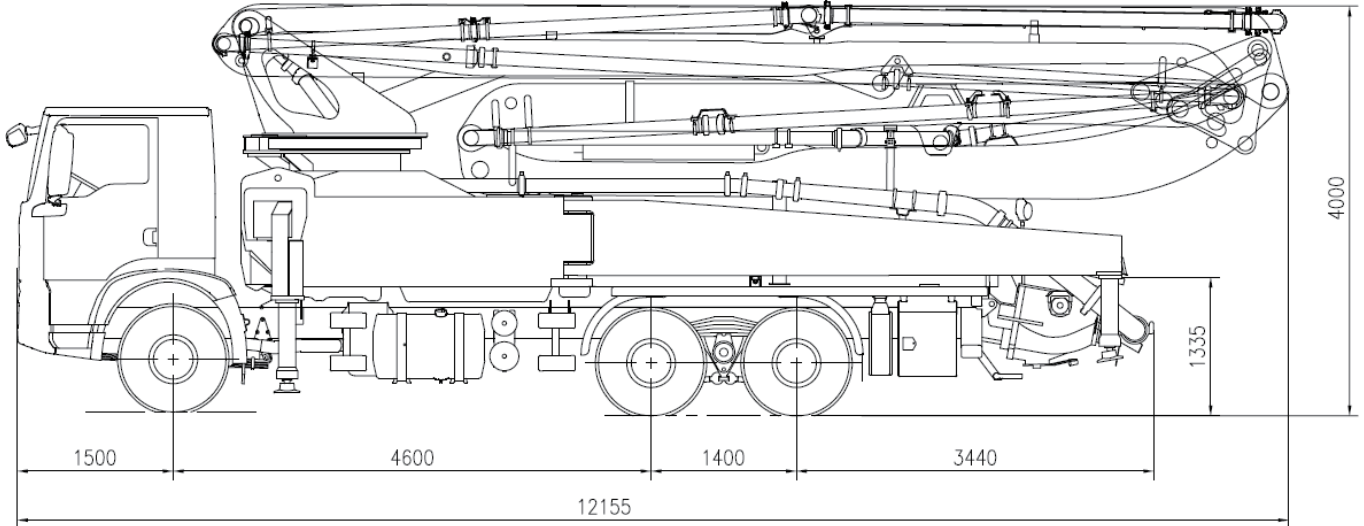

Note: Dimensions depend on truck.
Dimensions in mm.

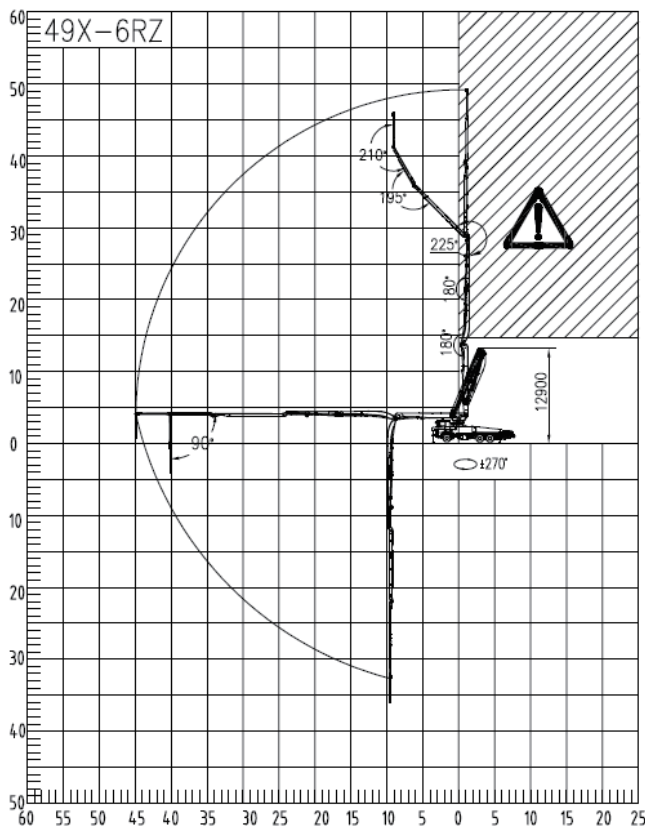

! : Range in which forbid to work.

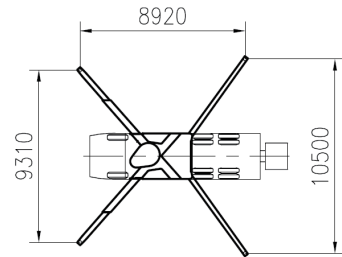

Full support

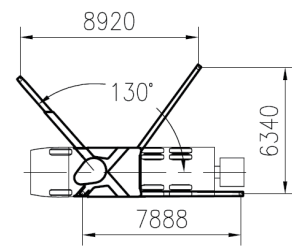

One side support

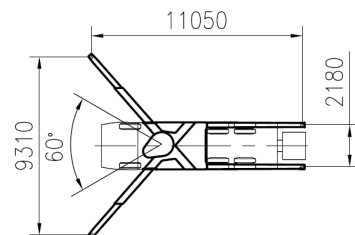

Front support

