

# ZOOMLION ROUGH TERRAIN CRANE ZRT1300V552



**ZOOMLION**

**ZOOMLION**

**Zoomlion Heavy Industry Science & Technology Co.,Ltd.**

Add: No.677, Lugu Road, Zoomlion Industrial Park, Changsha, Hunan, China, 410205

Copyright©2024 Zoomlion. All rights reserved. Reproduction and copying of any part of contents is not allowed for any purposes without Zoomlion's approval.



Product specifications are subject to change without notice and obligation. The photographs and/or drawing in this document are for illustrative purposes only. Please consult your local ZOOMLION dealer for more information.  
website:en.zoomlion.com 2024.04.03

# CONTENTS

PRODUCT INTRODUCTION .....	2
DIMENSIONS .....	2
LIFTING HEIGHT CURVE .....	3
LIFTING CAPACITY TABLES .....	3-7
TECHNICAL SPECIFICATIONS .....	7-10
TECHNICAL PARAMETERS .....	11-12

## PRODUCT INTRODUCTION

ZRT1300V552 rough terrain crane is adapted to narrow work space through its wide tread, high stability, short wheelbase and small turning radius.

It provides a 360° slewing function, 'on-tires' lifts and pick-and-carry operations.

It can be widely used in construction building sites, oil fields, warehouses, freight yards and logistics bases etc., to carry out lifting work, short distance transportation and pick-and-carry operations in narrow working areas.

ZRT1300V552 rough terrain crane consists of a superstructure and a special purpose chassis, including a power system, drive system, suspension system, steering system, braking system, hoist mechanism, derricking mechanism, slewing mechanism, boom system, turntable, chassis frame, outrigger, hydraulic system, electric system and cab etc.

Its distinguishing characteristics include:

-Four steering modes:

2-wheel steering (front wheels), 2-wheel steering (rear wheels), 4-wheel steering and crab steering.

-Max. rated lifting capacity: 130 ton at 2.5 m working radius.

-Max. lifting height: 66.7m.

-Max. driving speed: 30 km/h.

-Overall dimensions: 15355 mm x 3400 mm x 3970mm.

-Deadweight: 62.5 tons.

-Ability to pick-and carry loads.

-Ability to travel on rough terrains.

## DIMENSIONS

Overall View – ZRT1300V552 Rough Terrain Crane

Unit: mm

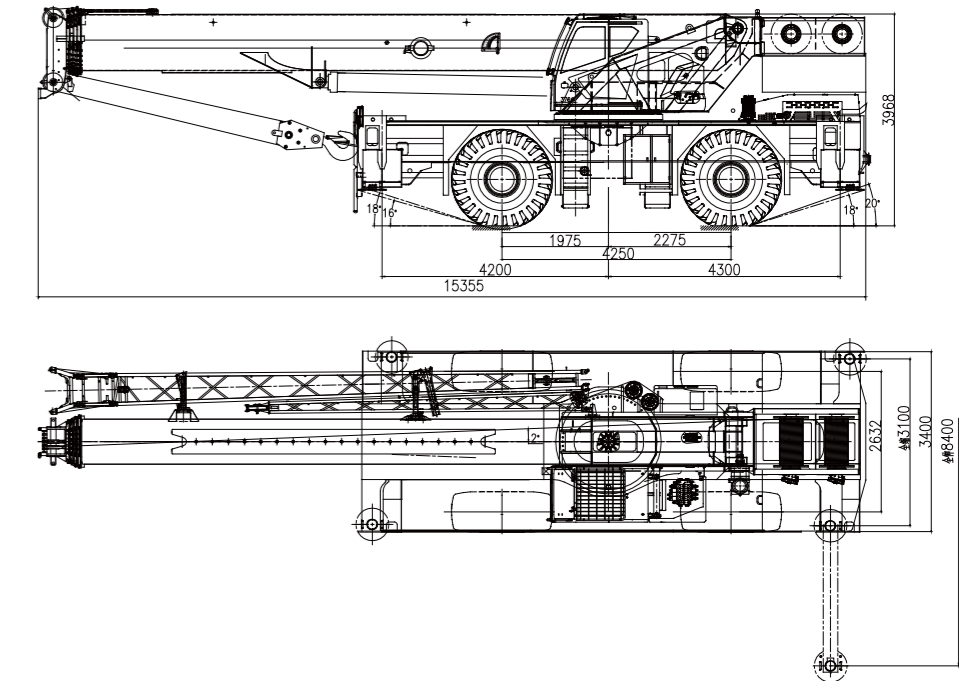

# LIFTING HEIGHT CURVE

Lifting height chart on outriggers fully extended with jib installed

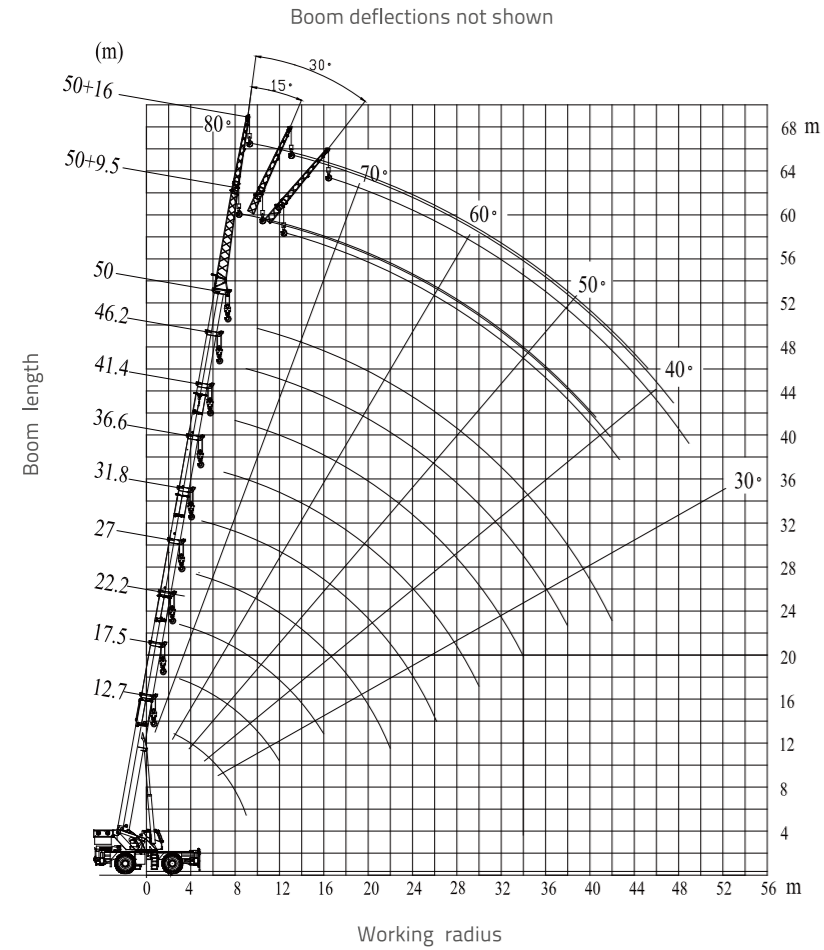

# RATED CAPACITY CHARTS

Rated capacity chart with boom on outriggers fully extended

BOOM

360° slewing  
(UNIT: T)

OUTRIGGERS FULLY EXTENDED

Working radius (m)	Telescopic cylinder I fully extended, outriggers fully extended, 14.5t counterweight								
	12.7	17.5	22.2	27.0	31.8	36.6	41.4	46.2	50.0
2.5	130.0*								
3.0	110.0*	70.0	50.0						
3.5	96.0*	70.0	50.0						
4.0	86.0*	70.0	50.0	38.0					
4.5	80.0*	70.0	50.0	38.0					
5.0	73.0*	65.0	50.0	38.0	36.0				
5.5	69.0	60.0	48.0	38.0	36.0				
6.0	64.0	55.0	46.5	37.0	36.0				
7.0	53.0	47.0	42.0	36.0	35.0	31.0			
8.0	45.0	41.0	38.0	34.0	33.0	30.0	22.0		
9.0	36.0	35.5	35.0	32.0	30.0	28.0	22.0	19.0	
10.0		31.4	31.0	29.0	27.5	26.0	21.0	18.0	14.5
11.0		26.0	25.7	27.0	25.5	24.0	20.0	17.0	14.0
12.0		21.8	21.5	22.7	23.5	22.0	18.5	16.0	13.5
14.0			15.5	16.7	17.5	18.3	16.0	14.0	13.0
16.0			11.5	12.7	13.5	14.2	14.6	12.5	11.5
18.0				9.9	10.7	11.4	11.8	11.5	10.5
20.0				7.9	8.6	9.2	9.6	10.0	9.5
22.0				6.2	6.9	7.5	7.9	8.3	8.6
24.0					5.6	6.2	6.5	6.9	7.2
26.0					4.5	5.1	5.4	5.8	6.0
28.0						4.2	4.5	4.9	5.1
30.0						3.4	3.7	4.1	4.3
32.0							3.1	3.4	3.6
34.0							2.5	2.8	3.0
36.0								2.4	2.5
38.0								2.0	2.1
40.0									1.7
42.0									1.4
I	0	4.8	9.5	9.5	9.5	9.5	9.5	9.5	9.5
II	0	0	0	4.8	9.6	14.4	19.2	24.0	27.8
Reeving	12	11	8	7	6	5	4	3	3
Hook	70t								

# RATED CAPACITY CHARTS

Rated capacity chart with boom on outriggers fully extended

BOOM

360° slewing  
(UNIT: T)

OUTRIGGERS FULLY EXTENDED

Working radius (m)	Telescopic cylinder I fully extended, outriggers fully extended, 14.5t counterweight							
	12.7	17.5	22.3	27.1	31.9	36.7	41.5	45.3
2.5	130.0*							
3.0	110.0*	70.0	38.0					
3.5	96.0*	70.0	38.0					
4.0	86.0*	70.0	38.0	36.0				
4.5	80.0*	70.0	38.0	36.0				
5.0	73.0*	65.0	38.0	36.0	30.0			
5.5	69.0	60.0	38.0	36.0	30.0			
6.0	64.0	55.0	38.0	36.0	30.0	22.0		
7.0	53.0	47.0	38.0	36.0	30.0	22.0		
8.0	45.0	41.0	36.0	36.0	30.0	22.0	19.5	
9.0	36.0	35.5	34.0	35.0	29.0	21.0	18.5	16.0
10.0		31.4	32.0	33.0	27.0	20.0	17.5	15.0
11.0		26.0	27.5	28.5	26.0	18.7	16.5	14.0
12.0		21.8	22.9	23.9	24.0	17.5	15.5	13.5
14.0			17.1	18.1	18.6	15.2	13.5	12.5
16.0			13.2	14.2	14.7	13.5	12.0	11.0
18.0				11.3	11.8	12.1	10.6	10.0
20.0				9.1	9.6	10.0	9.6	9.1
22.0				7.5	8.0	8.4	8.7	8.3
24.0					6.7	7.0	7.3	7.6
26.0					5.6	5.9	6.2	6.4
28.0						5.0	5.3	5.5
30.0						4.2	4.5	4.7
32.0							3.8	4.0
34.0							3.2	3.4
36.0								2.9
38.0								2.5
I	0	4.8	4.8	4.8	4.8	4.8	4.8	4.8
II	0	0	4.8	9.6	14.4	19.2	24.0	27.8
Reeving	12	11	8	7	6	5	4	3
Hook	70t							

BOOM

360° slewing  
(UNIT: T)

OUTRIGGERS FULLY EXTENDED

Working radius (m)	TELESCOPIC CYLINDER I FULLY EXTENDED, outriggers fully extended, 6.8t counterweight						
	12.7	17.5	22.3	27.1	31.9	36.7	40.5
2.5	130.0*						
3.0	110.0*	38.0	36.0				
3.5	96.0*	38.0	36.0				
4.0	86.0*	38.0	36.0	30.0			
4.5	80.0*	38.0	36.0	30.0			
5.0	73.0*	38.0	36.0	30.0	22.0		
5.5	69.0	38.0	36.0	30.0	22.0		
6.0	64.0	38.0	36.0	30.0	22.0	21.0	
7.0	53.0	38.0	36.0	30.0	22.0	20.0	
8.0	45.0	38.0	34.0	28.0	20.5	18.7	17.0
9.0	36.0	36.0	32.0	26.0	19.0	17.2	16.0
10.0		33.0	31.0	24.0	17.5	16.0	15.0
11.0		28.0	29.0	22.0	16.0	14.5	14.0
12.0		24.0	25.0	20.5	15.0	13.5	13.0
14.0			19.1	18.0	13.0	12.0	11.3
16.0			15.0	15.5	11.5	10.5	10.0
18.0				12.5	10.3	9.4	9.0
20.0				10.4	9.3	8.4	8.0
22.0				8.7	8.5	7.7	7.2
24.0					7.8	7.0	6.6
26.0					6.6	6.4	6.0
28.0						5.8	5.4
30.0						5.1	5.0
32.0							4.6
34.0							4.0
I	0	0	0	0	0	0	0
II	0	4.8	9.6	14.4	19.2	24.0	27.8
Reeving	12	11	8	7	6	5	4
Hook	70t						

## NOTES

a)It is necessary to use a hook with higher lifting capacity if the rated lifting capacity exceeds 70T, and special devices are required for operating modes marked with \* in the table.

b)Crane load ratings are based on the crane being leveled and standing on a firm and uniform supporting surface.

c)Crane load ratings on outriggers are based on all outrigger beams being positioned according to the applicable lift chart and the tires raised free of the supporting surface.

d)CRANE LOAD RATINGS MUST NOT BE EXCEEDED. DO NOT ATTEMPT TO TIP THE CRANE TO DETERMINE ALLOWABLE LOADS.

e)Lift the load vertically. Do not pull the load at an angle.

f)When either radius or boom length, or both, are between listed values, the smaller of the two listed load ratings shall be used.

g)The boom angles shown on the lift charts give an approximation of the operating radius for a specified boom length. The boom angle, before loading, should be greater to account for boom deflection.

h)Rated loads include the weight of hook block, slings, and auxiliary lifting devices. Their weights shall be subtracted from the listed rated load to obtain the net load that can be lifted.

i)Consult appropriate section of the Operator's Manual for more exact description of hoist line

reeving.

j)Properly maintained wire rope is essential for safe crane operation. Consult the Operator's Manual and Maintenance Manual for proper maintenance and inspection requirements.

k)When the rotation-resistant wire rope is used, the allowable rope loading shall be the breaking strength divided by five (5), unless otherwise specified by the wire rope manufacturer.

l)When an anti-twist wire rope is used, unless otherwise specified, the permissible load of the wire rope should be a fifth of the tensile strength.



m)The user shall operate at reduced ratings to allow for adverse job conditions, such as: soft or uneven ground, out of level conditions, high winds, side loads, pendulum action, jerking or sudden stopping off loads, hazardous conditions, experience of personnel, two-machine lifts, traveling with loads, electric wires, etc, (side pull on boom or jib is hazardous). If the wind speed is higher than the maximum permissible value (45 ft/s (13.8 m/s), grade 6) or it is fulminous during crane operation, stop the work, fully retract the boom and correctly stow the boom.

n)Load ratings are dependent upon the crane being maintained according to the Operator's

Manual and Maintenance Manual.

## RATED CAPACITY CHARTS

Rated capacity chart with boom + jib on outriggers fully extended

		360° slewing (UNIT: t)				
Boom + jib				OUTRIGGERS FULLY EXTENDED		
Boom angle (°)	Outriggers fully extended, 14.5t counterweight					
	50.0 + 9.5			50.0 + 16.0		
	0°	15°	30°	0°	15°	30°
80	5.5	3.3	2.5	3	2	1.5
78	5.0	3.3	2.5	3	2	1.45
76	4.8	3.2	2.5	2.9	1.9	1.4
74	4.5	3.1	2.5	2.7	1.8	1.35
72	4.2	3.0	2.5	2.5	1.7	1.3
70	3.9	2.9	2.4	2.3	1.65	1.25
68	3.6	2.8	2.3	2.1	1.6	1.25
66	3.4	2.7	2.2	2	1.55	1.2
64	3.2	2.6	2.1	1.9	1.5	1.2
62	3.0	2.5	2.05	1.8	1.45	1.15
60	2.8	2.4	2	1.7	1.4	1.15
58	2.7	2.3	1.95	1.6	1.35	1.1
56	2.6	2.2	1.9	1.55	1.3	1.1
54	2.5	2.1	1.85	1.5	1.25	1.05
52	2.2	2.0	1.8	1.45	1.2	1.05
50	1.9	1.8	1.7	1.4	1.15	1
48	1.7	1.6	1.5	1.35	1.1	0.95
46	1.5	1.4	1.3	1.2	1.05	0.9
44	1.3	1.2	1.1	1.0	0.9	0.85
42	1.1	1.0	0.9	0.8	0.75	0.7
40	0.9	0.8	0.7			
Reeving	1					
Hook	8t					

## NOTES

a)Crane load ratings are based on the crane being leveled and standing on a firm and uniform supporting surface.

b)Crane load ratings on outriggers are based on all outrigger beams being positioned according to the applicable lift chart and the tires raised free of the supporting surface.

c)CRANE LOAD RATINGS MUST NOT BE EXCEEDED. DO NOT ATTEMPT TO TIP THE CRANE TO DETERMINE ALLOWABLE LOADS.

d)Lift the load vertically. Do not pull the load at an angle.

e)When either radius or boom length, or both, are between listed values, the smaller of the two listed load ratings shall be used.

f)The boom angles shown on the lift charts give an approximation of the operating radius for a specified boom length. The boom angle, before loading, should be greater to account for boom deflection.

g)Rated loads include the weight of hook block, slings, and auxiliary lifting devices. Their weights shall be subtracted from the listed rated load to obtain the net load that can be lifted.

h)Consult appropriate section of the Operator's Manual for more exact description of hoist line

reeving.

i)Properly maintained wire rope is essential for safe crane operation. Consult the Operator's Manual and Maintenance Manual for proper maintenance and inspection requirements.

j)When the rotation-resistant wire rope is used, the allowable rope loading shall be the breaking strength divided by five (5), unless otherwise specified by the wire rope manufacturer.

k)The user shall operate at reduced ratings to allow for adverse job conditions, such as: soft or uneven ground, out of level conditions, high winds, side loads, pendulum action, jerking or sudden stopping off loads, hazardous conditions, experience of personnel, two-machine lifts, traveling with loads, electric wires, etc, (side pull on boom or jib is hazardous). If the wind speed is higher than the maximum permissible value (45 ft/s (13.8 m/s), grade 6) or it is fulminous during crane operation, stop the work, fully retract the boom and correctly stow the boom.

l)Load ratings are dependent upon the crane being maintained according to the Operator's

Manual and Maintenance Manual.

## RATED CAPACITY CHARTS

Rated capacity chart on tires

Load radius (m)	12.7		17.5		22.3		27.1	
	360°	Travel over front	360°	Travel over front	360°	Travel over front	360°	Travel over front
4.5		11.5						
5.0		10.3		10.6				
5.5		9.0		9.3		9.7		9.9
6		8.2		8.5		8.9		9.1
7	5.6	6.5	6.5	6.8	7.0	7.1	7.4	7.3
8	4.2	5.2	5.1	5.5	5.6	5.8	6.0	6.0
9	3.0	3.8	3.9	4.6	4.4	4.9	4.8	5.1
10			3.0	3.9	3.5	4.2	3.8	4.4
11			2.3	3.2	2.7	3.4	3.0	3.6
12			1.8	2.6	2.2	2.8	2.5	2.9
14				1.6	1.4	1.8	1.7	1.9
16						1.2		1.4
I	0		0		0		0	
II	0		4.8		9.6		14.4	
Reeving	4		4		4		4	
Hook	70t							

Note: 360° working range is applicable to crane standstill.

## NOTES

a Crane load ratings are based on the crane being leveled and standing on a firm and uniform supporting surface.

b CRANE LOAD RATINGS MUST NOT BE EXCEEDED. DO NOT ATTEMPT TO TIP THE CRANE TO DETERMINE ALLOWABLE LOADS.

c Lift the load vertically. Do not pull the load at an angle.

d When either radius or boom length, or both, are between listed values, the smaller of the two listed load ratings shall be used.

e The boom angles shown on the lift charts give an approximation of the operating radius for a specified boom length. The boom angle, before loading, should be greater to account for boom deflection.

f Rated loads include the weight of hook block, slings, and auxiliary lifting devices. Their weights shall be subtracted from the listed rated load to obtain the net load that can be lifted.

g Crane load ratings on tires depend on appropriate inflation pressure and tire condition. Caution must be exercised when increasing air pressures in tires. Consult the Operator's Manual for precautions.

h Use of jib is not permitted for pick-and-carry operations.

i For pick-and-carry operations, the boom must be centered over the front of the crane with the swing brake lock engaged. Use minimum boom point height and keep the load close to the ground surface. Travel must be on smooth level surface.

j The load should be restrained from swinging.

k Creep speed is crane movement of less than 200 ft (61 m) in 30-minutes period and not exceeding 1 mph (1.6 km/h).

l Consult appropriate section of the Operator's Manual for more exact description of hoist line reeving.

m The use of more parts of line than required by the load may result in having insufficient rope to allow the hook block to reach the ground. Choose the correct line parts to get a rope in the proper length. Refer to Table 1.1.

a) Properly maintained wire rope is essential for safe crane operation. Consult the Operator's Manual and Maintenance Manual for proper maintenance and inspection requirements.

b) When the rotation-resistant wire rope is used, the allowable rope loading shall be the breaking strength divided by five (5), unless otherwise specified by the wire rope manufacturer.

c) The user shall operate at reduced ratings to allow for adverse job conditions, such as: soft or uneven ground, out of level conditions, high winds, side loads, pendulum action, jerking or

sudden stopping off loads, hazardous conditions, experience of personnel, two-machine lifts, traveling with loads, electric wires, etc. (side pull on boom or jib is hazardous). If the wind speed is higher than the maximum permissible value (45 ft/s (13.8 m/s), grade 6) or it is fulminous during crane operation, stop the work, fully retract the boom and correctly stow the boom.

d) Load ratings are dependent upon the crane being maintained according to the Operator's Manual and Maintenance Manual.

## TECHNICAL SPECIFICATIONS



### BOOM AND TELESCOPING MECHANISM

The box-shaped telescopic boom consists of 5 U-type boom sections made of high-strength steel.

The telescopic boom sections are telescoped in / out via two telescopic cylinders and two sets of boom extension/retraction ropes. Each telescopic cylinder is equipped with a plug-in balance valve.

The boom head is equipped with 6 pulleys, which is convenient for changing wire rope reeving without removing the wedges. A rooster sheave is optional.

Min. boom length (with telescopic sections completely retracted): 12700mm Max. boom length (with telescopic sections completely extended): 50000mm Min. telescoping out time: 150 s.



### JIB

It consists of two lattice jib sections. The jib section II is secured into the jib section I, and the whole jib is stowed to one side of the boom via moveable pins during driving.

A single pulley is assembled at the jib head. Angle: 0°, 15° and 30° Jib length: 9.5m, 16 m.



### DERRICKING MECHANISM

A front-mounted single derricking cylinder is installed with a derricking balance valve. Derricking angle range 1° - 80°.

Derricking speed 1° - 80° / 70s.



### HOIST MECHANISM

Main and auxiliary winches

The main winch realizes lifting and lowering movements through rotations of the drum driven by the planetary reducer which is driven by the axial variable plunger pump.

The auxiliary winch is optional.

Wire rope

High strength wire rope

Max. hoist rope tensile force: 8500 kg.

Max. hoist rope speed: 130 m/min (At the 4th layer).

Rope diameter: Φ20 mm.

Main winch rope length: 260 m.

Auxiliary winch rope length: 140m.

Hook block

Rotatable main hook: 70 t, with 6 pulleys and a hook latch, secured at the chassis frame in front of slewing table.

Rotatable auxiliary hook: 8 t, with a hook latch, used with the rooster sheave and jib, secured at the auxiliary hook holder on the chassis frame.

Rotatable hook: 90 t (optional), with 6 pulleys and a hook latch, secured at the chassis frame in front of the slewing table.

## TECHNICAL SPECIFICATIONS



### SLEWING MECHANISM

It consists of a hydraulic motor, planetary gear reducer, pinion gear and slewing ring, etc. Via the planetary gear reducer, the hydraulic motor drives the pinion gear to rotate and makes the slewing bearing's outer ring rotate around its inner toothed ring fixed on chassis frame, realizing 360° unlimited superstructure slewing.

Hydraulically controlled usually-closed brake realizes controlled slewing function of the slewing mechanism.

Slewing speed: 0 - 1.6r/min.



### TURNTABLE

The turntable adopts a wall plate structure.



### HYDRAULIC SYSTEM

Oil pump

The two variable pumps together supply hydraulic oil to the telescoping, derricking and hoist mechanisms. Moreover, the two pumps also supply pilot oil.

One gear pump supplies hydraulic oil to braking system, oil radiator of chassis torque converter, and superstructure AC.

The other gear pump supplies hydraulic oil to outriggers, slewing and steering systems.

Control valve

A quadruple multi-way directional valve which adopts downstream pressure compensation technology.

Pipeline

An air-cooled hydraulic oil cooler driven by an electric motor is located in the return line.

The system pressure can be displayed on the instrument console. There are pressure test ports configured in hydraulic lines.

Hydraulic oil tank

Capacity: about 1300 L.

The return oil filter can eliminate bubbles. The filtering accuracy is 10µm.



### CRANE CONTROLS

The superstructure movements are controlled by two hydraulic joysticks (with a cross shaft) on both sides of operator's seat (complying with ISO standard requirements).

The left joystick controls slewing and auxiliary winch movements The right joystick controls derricking and main winch movements.

Derricking and telescoping movements can be executed simultaneously.



### CAB

There is only one cab for ZRT1300 rough terrain crane. It can be used as the operator's cab as well as the driver's cab. The cab is side-mounted and adopts left hand drive.

There are two control boxes on the both sides of operator's seat. The left / right control box can be pulled up. Controls of the superstructure are arranged according to the requirements of ASME B30.5-2007 standard and comply with ISO (International Organization for Standardization) standard.

Cab dimensions:

Length: 1810±5mm.

Width: 1050±5mm.

Height: 1710±5mm.



### RATED CAPACITY INDICATOR (RCI)

If the actual load approaches the rated one, the buzzer sends out visual and audible warning.

If the actual load reaches the rated one, all dangerous movements are switched off automatically.

The rated capacity indicator can also limit the working range (including working radius, boom angle, lifting height and slewing range etc.).

The following information can be displayed on the screen:

- Boom angle or moment ratio;

- Boom length or default hook weight;

- Actual working radius or slewing angle;

- Actual lifting capacity;

- Max. permissible lifting capacity;

- Jib installation angle or wire rope reeving;

- Boom status indication;

- Outrigger status or "On Tires" indication. The following information is displayed by bar graph:

- Percentage of actual lifting capacity to the rated one or working pressure of the hydraulic system.

# TECHNICAL SPECIFICATIONS

## OUTRIGGERS

H-type outriggers, hydraulically controlled, can be operated in the cab simultaneously or independently. Each vertical jack cylinder is equipped with a two-way hydraulic lock to ensure that outriggers are secured reliably during working or driving.

Outrigger boxes are directly welded onto the chassis frame.

The outriggers can be completely extended, half extended or completely retracted for different operating modes.

Outrigger spread (Height): 8500mm.

Outrigger spread (Width): 8400 mm (fully extended), 5800 mm (half extended) 3140 mm (fully retracted).

## TYPE

Rear-mounted engine, left-hand drive  
Drive mode: 4 x 2 and 4 x 4.

## CHASSIS FRAME

An Integral box-type structure welded by high-strength steel.

## ENGINE

Model  
CUMMINS B6.7.  
Type  
Four-stroke, 6-cylinder, direct injection, water-cooled, turbocharged diesel engine.  
Performance  
Max. output power:194 KW / 2500 RPM (US Cummins) Max. output torque: 1152 Nm / 1500 RPM.

## DRIVE SYSTEM

Electrically controlled automatic hydraulic transmission, capable of four-wheel drive mode when the transmission drives both the front and rear axles, as well as rear-wheel drive mode when the transmission disengages from the front axle and only drives the rear axle.

6 forwards and 6 reverse speeds, electric-hydraulic power gear shift, with an automatic locking mechanism.

The working hydraulic oil pump and steering oil pump directly take off power from the transmission.

## AXLES

Front axle  
Steering and driving axle, rigidly mounted to the chassis frame, with a planetary reducer and brake.

Rear axle  
Full-floating steering and driving axle, with a planetary reducer and brake.

## STEERING SYSTEM

Fully hydraulic power steering gear  
The cylinder of the steering and driving axles is controlled by steering wheel to realize crane steering.

4 steering modes:  
2-wheel steering – front wheel steering  
2-wheel steering – rear wheel steering  
4-wheel steering – all-wheel steering.  
4-wheel steering – crab steering.

## SUSPENSION SYSTEM

Front axle: rigidly mounted to the chassis frame.  
Rear axle: a swing axle, connecting to the chassis frame via a hydraulic suspension cylinder.

## BRAKING SYSTEM

Service brake  
Hydraulically controlled disc brake acting on 4 wheels.

Parking brake  
Hydraulically released parking brake, acted on by the spring mounted on the input shaft of front axle.

## ELECTRICAL SYSTEM

24 Volt DC  
2 batteries with 12 V rated voltage and 120 Ah rated current.

## FUEL TANK

Capacity:300 L.

## Tire

Size:29.5-25-34PR.

## Safety devices

Rated capacity indicator (RCI).  
Rotating beacon and horn.  
Hoisting limiter (anti-two block, ATB).  
Lowering limiter (3rd wrap indicator).  
Balance valve.  
Hydraulic lock.  
Hydraulic safety valve.  
Slewing braking mechanism.  
Slewing lockout device.  
Boom angle indicator.  
Outrigger beam retaining pin.  
Emergency stop button.

## TECHNICAL PARAMETERS

Type	Item	Unit	Value
Working performance	Max. rated lifting capacity × working radius	kg.m	130000×2.5
	Max. load moment of the boom	kN.m	3760
	Max. load moment of the boom (fully extended)	kN.m	1862
	Max. lifting height of the boom (fully extended)	m	50.5
	Max. lifting height of the jib	m	66.7
Dimensions	Overall dimensions (L × W × H)	mm	15355×3400×3970
	Outrigger spread (Height × Width)	mm	8500×8400
	Boom length	mm	12700-50000
	Jib length	mm	9500, 16000
	Boom angle	°	-1-80
	Slewing range		360° unlimited slewing (Full range)
Working speeds	Max. hoist rope speed (Main winch)	m/min	130
	Min. boom telescoping out time	s	150
	Min. boom telescoping in time	s	170
	Min. boom derricking up time	s	70
	Min. boom derricking down time	s	155
	Slewing speed	r/min	0-1.6
Hydraulic system	Maximum working pressure	MPa	28
	Rate working flow	L/min	320
	Hydraulic oil tank capacity	L	1300
Gross vehicle mass	Gross weight	kg	62500
	Front weight	kg	31500
	Rear weight	kg	31000
Driving	Max. driving speed	km/h	30/30
	Wheelbase	mm	4250
	Treads(Front / Rear)	mm	2565
	Max. gradeability	%	75%

## TECHNICAL PARAMETERS

Type	Item	Unit	Value
Power system	Engine make & model		Cummins B6.7
	Fuel type		Diesel
	Intake system		Turbo-charged, air to air, inter-cooling
	Cooling system		Water-cooling
	Engine rated power	KW/r/min	194KW/2500rpm (US Cummins)
	Engine rated torque	N.m/r/min	1152N.m/1500rpm
	Fuel tank capacity		300 L
Drive system	Transmission drive mode		4×2, 4×4
	Model or brand of transmission		DANA
	Transmission gear stage		6 forward and 6 reverse speeds
Travel system	Suspension		Rigid (front) / Flexible (rear)
	Model or brand of axles		Meritor
	Steering mode		2-wheel steering (front wheels) 2-wheel steering (rear wheels) 4-wheel steering Crab steering
	Tire size		29.5-25-34PR
	Tire number		4
Hydraulic system	Model or brand of main valve		ZOOMLION
	Plunger pump		HIGH-TECH (China)
	Balance valve / hydraulic lock		ZOOMLION
Electrical system	Rated capacity indicator		ZOOMLION/HIRSCHMANN
Emission			Euro V